

High efficiency in dispensing because a large amount of liquid is contained in the tank.  
 High responsiveness thanks to the various standardized options according to the characteristics of the liquids and the customers' needs (electrolytic polishing, Teflon coating, etc.)  
 Safety-certificated type can be custom-made to enhance work site stability.  
 As our products are standardized in various types of capacities (1-50L), with a method of inputting liquid directly and a method of using internal containers, we have the system that can be immediately delivered.

《《《 By applying Taeha's advanced dispensing expertise and our highly reliable pressure tank, we propose the most suitable applications for customers.

— Tank Specifications

Material	SUS304
Cover Type	Ferrule Clamp Type
Material Outlet	Bottom port(BSPT3/8", Female) *option : Top port
Polishing	Buff Polishing
Sealing	O-Ring(NBR), Capsule O-Ring(Viton) Silicone O-Ring, EPDM O-Ring
Operating Pressure	0.5MPa

〈TANK of OPTION〉

PRESSURE REGULATOR

Model	Description
TRS-04	G-Medium pressure type, 0~0.4Mpa
TRS-07	G-High pressure type, 0~0.7Mpa
TRS-04P	P-Medium pressure type, 0~0.4Mpa
TRS-07P	P-High pressure type, 0~0.7Mpa

\* G : General type, P : Precise type

MATERIAL INLET PORT

1.5S/2S/2.5S/3S Ferrule Clamp type  
 (The size of the pipe connecting depends on the size of clamp)

AGITATOR

Model	Motor	Use Tank
TAU-20S	DC Motor, 20W, □60mm	1L, 3L, 5L
TAU-90S	DC Motor, 90W, □90mm	10L, 20L, 30L, 40L, 50L, 60L

SAFETY VALVE

TANK HEATING

Type	Operating Temp	Max.Voltage
Silicone Rubber Heater (for End plate)	-62°C ~ 260°C	380VAC
Aluminum Jacket Heater	-62°C ~ 150°C	380VAC



LEVEL PIPE

∅6 x ∅8 PFA Hose  
 PFA 1/2" Hose

LEVEL SENSOR

Model	Description
TLS-H	Floating type, SUS304, High-limit
TLS-L	Floating type, SUS304, Low-limit
TLS-HL	Floating type, SUS304, High/Low-limit

MATERIAL OUTLET PORT

BSPT 3/8

## Stainless Straight Round type (SSR Series)



Dimension

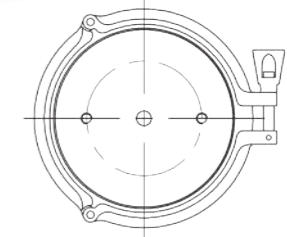

- A type that uses liquid put directly into the material.
- The wide opening makes it easy to add liquid materials and easy to clean.
- There is no liquid balance due to fluidity due to the lower plate structure.

Tank Size Unit(mm)

Model	A	B	C	D	E
SSR-1BP	245	153	∅142	∅97.6	2.0
SSR-3BP	280	174.1	∅205	∅159.6	2.8
SSR-5BP	353.5	249.1	∅205	∅159.6	2.8
SSR-10BP	433.7	311	∅265	∅210.3	3.0
SSR-20BP	728.7	605	∅265	∅210.3	3.0

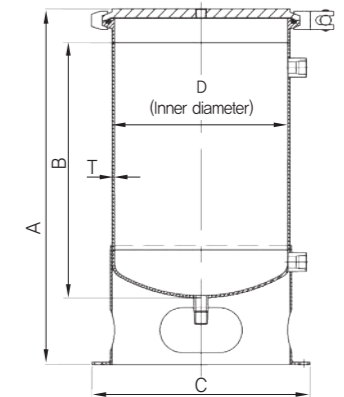

## Stainless Straight Flat type (SSF Series)



Dimension

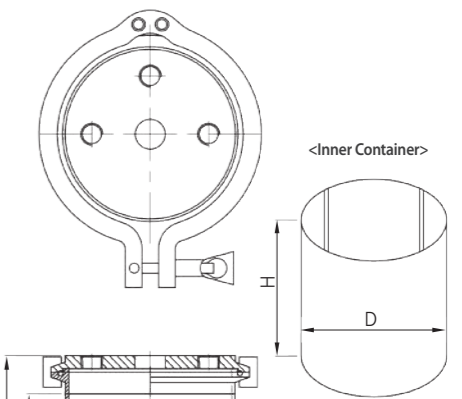

- Since the liquid is put into the inner container, there is no contact between the inside of the tank and the liquid.
- The wide opening makes it easy to add liquid materials and easy to clean.
- Suitable for acids, anaerobic liquids and two-component materials that react with metals.

Inner Container

- Material : SUS304(STD), PE/TEFLON(option) \*\*Internal surface : Teflon Coating (option)

Tank Size Unit(mm)

Model	A	B	D	T	Inner Container(∅DxH)
SSF-1TP	209	178	∅97.6	2.0	∅101.6x215
SSF-3TP	240.5	199	∅159.6	2.8	∅155x210
SSF-5TP	294.52	250	∅159.6	2.8	∅155x320
SSF-10TP	394.3	341	∅210.7	2.8	∅205x365
SSF-20TP	689.3	648	∅210.7	2.8	∅205x660

